

4FT-CHARTWELL TRIPLE

ASSEMBLY INSTRUCTIONS GUIDE

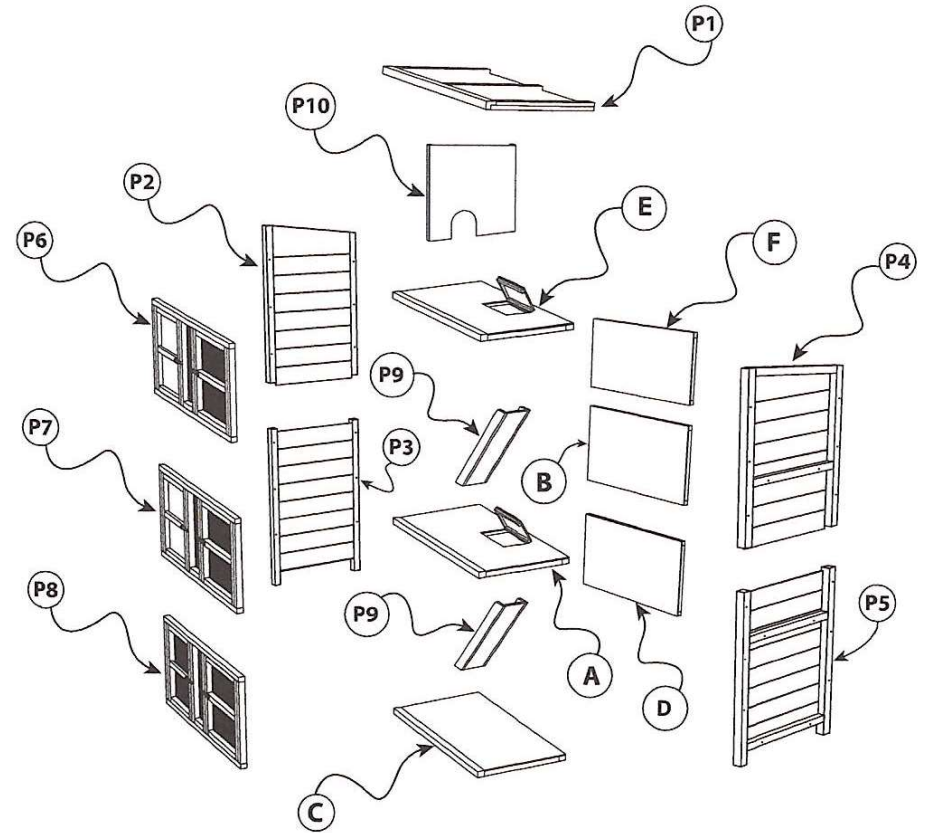

PART LIST					
PART NUMBER	PART NAME	QTY	PART NUMBER	PART NAME	QTY
P1	TOP	1	A	MIDDLE SHELF	1
P2	SIDE LEFT [UPPER PART]	1	B	MIDDLE BACK	1
P3	SIDE-LEFT [LOWER PART]	1	C	BOTTOM	1
P4	SIDE RIGHT [UPPER PART]	2	D	BOTTOMBACK	1
P5	SIDE-RIGHT [LOWER PART]	1	E	UPPER SHELF	1
P6	UPPER DOOR FRAME & DOOR	1	F	UPPER BACK	1
P7	MIDDLE DOOR FRAME & DOOR	1			
P8	LOWER DOOR FRAME & DOOR	1			
P9	LADER	2			
P10	PARTITION	1			

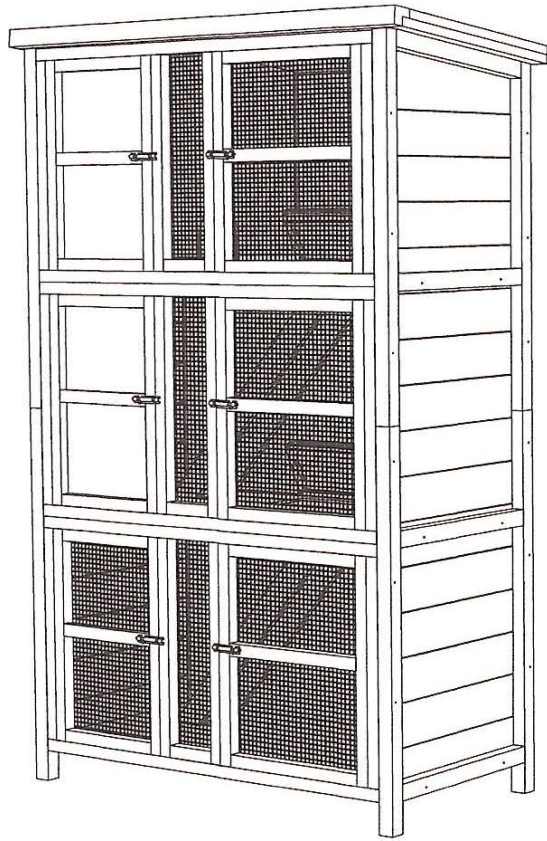

IMPORTANT NOTES

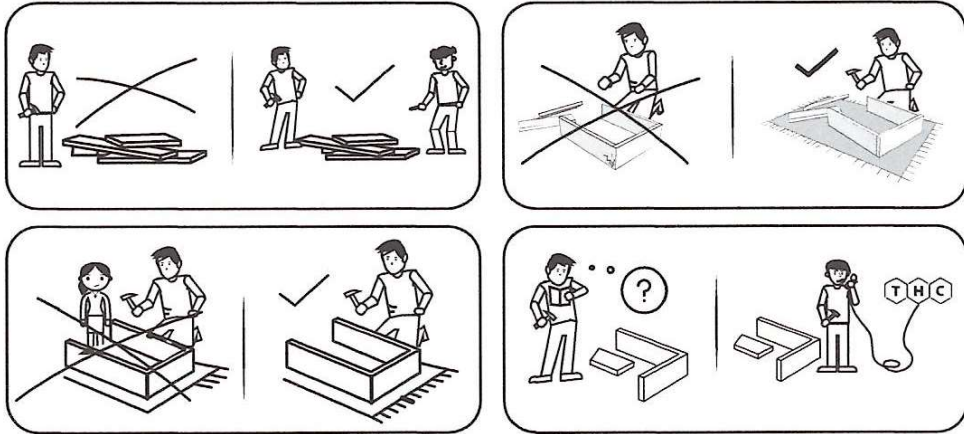

(A) Place all wooden parts on a clean and smooth surface such as a rug or carpet to avoid the parts from being scratched.

(B) Check to be sure that you have all parts and hardware.

(C) Keep all hardware parts out of reach of children

HARDWARE & TOOL DETAILS



HARDWARE LIST

NAME	SIZE/DMS	CODE	QTY
STAR SCREW	50 mm	1001	43 Nos
STAR SCREW	40 mm	1002	24 Nos
STAR SCREW	20 mm	1003	16 Nos
STAR SCREW DRIVER	NOT PROVIDED		

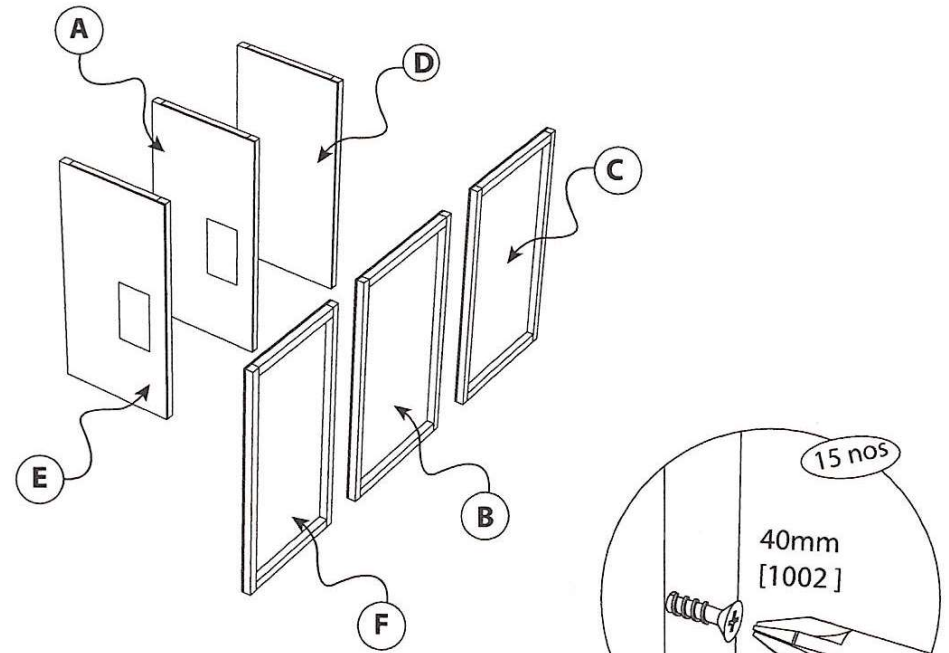

STEP:01

Attach [A with B], [C with D], [E with F]

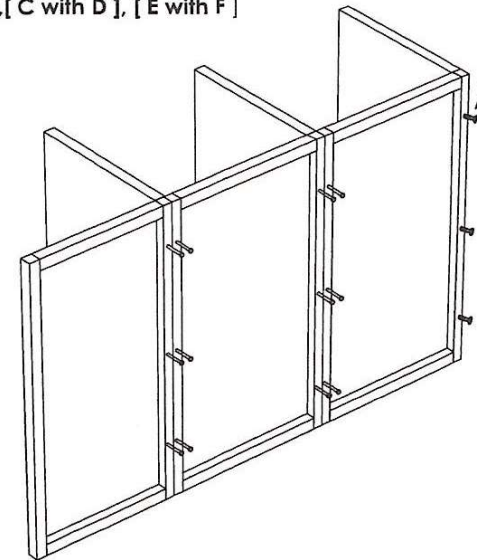

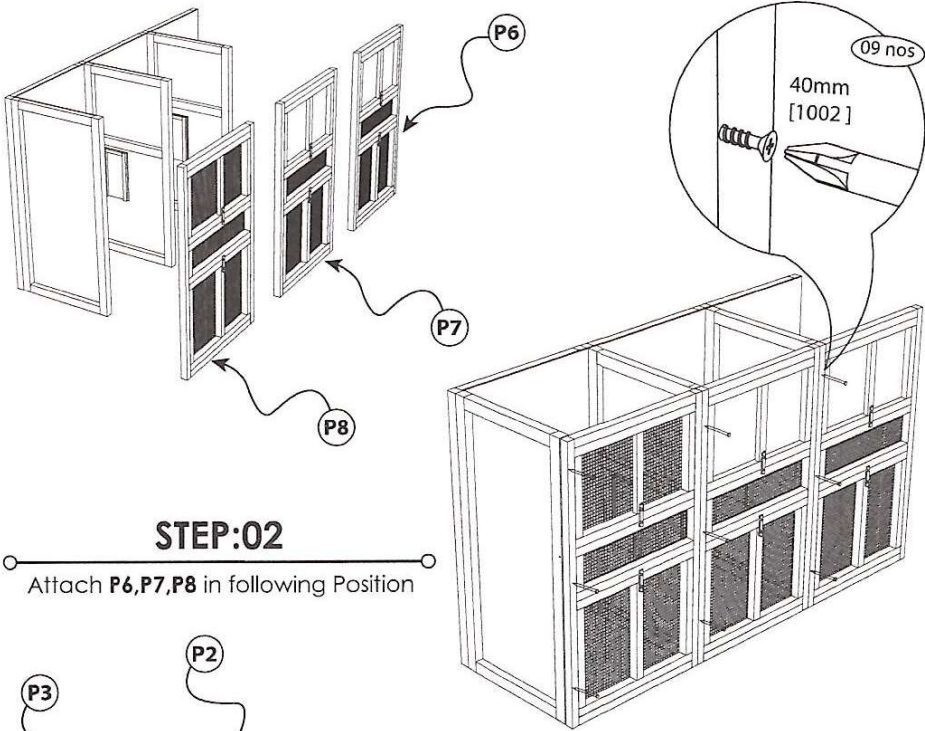

STEP:02

Attach **P6,P7,P8** in following Position

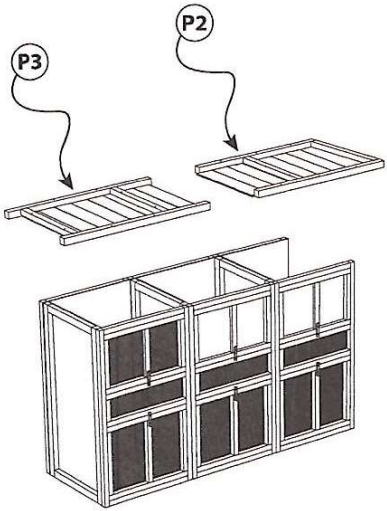

STEP:03

Attach **P2,P3** in following Position

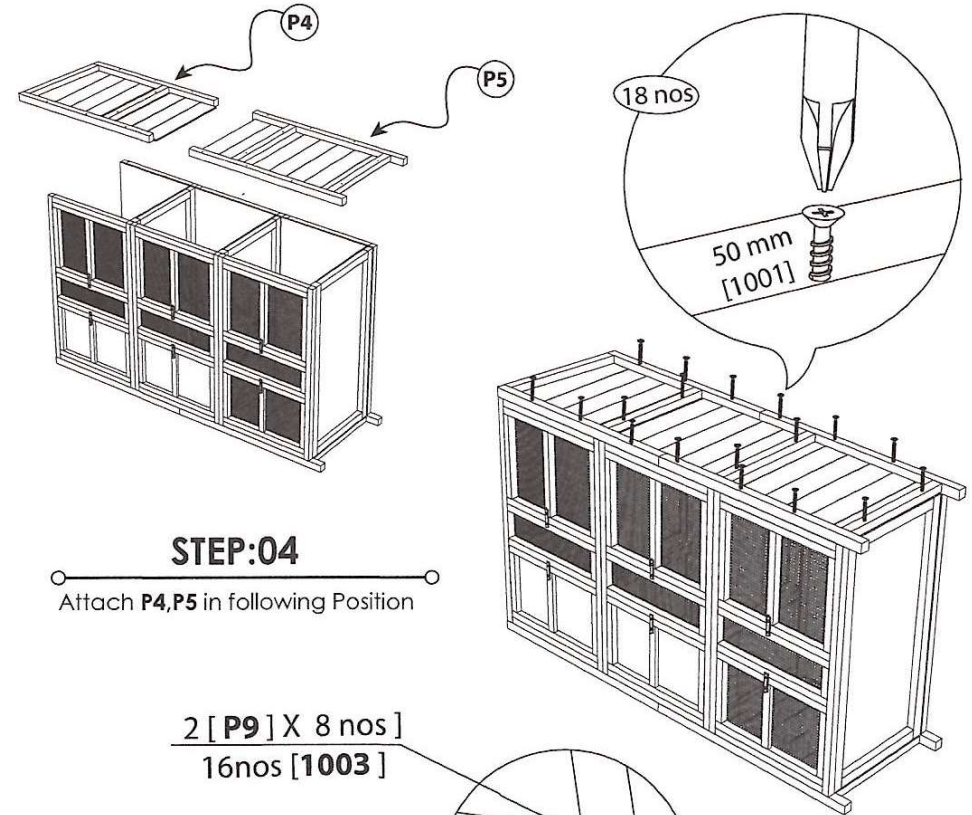

STEP:04

Attach **P4,P5** in following Position

2 [**P9**] X 8 nos]
16nos [**1003**]

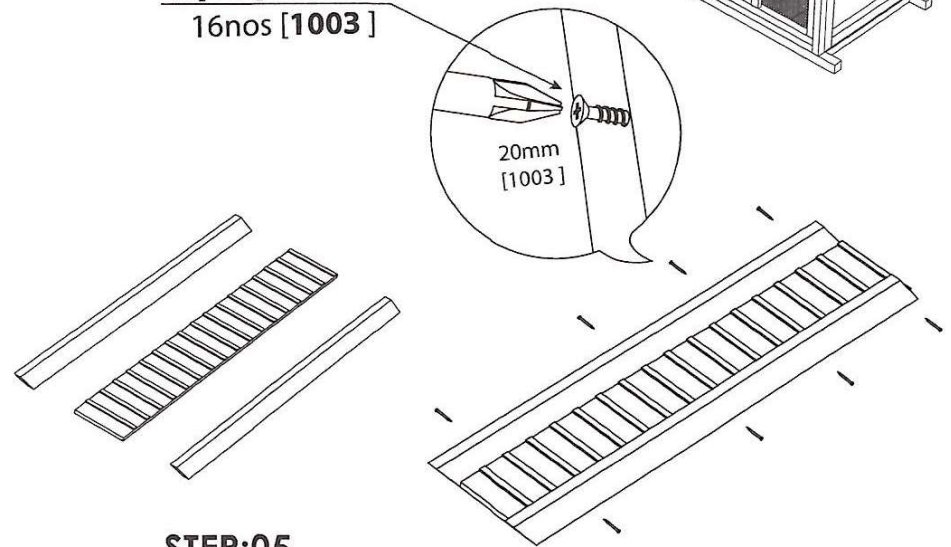

STEP:05

Assembl **P9** following this step

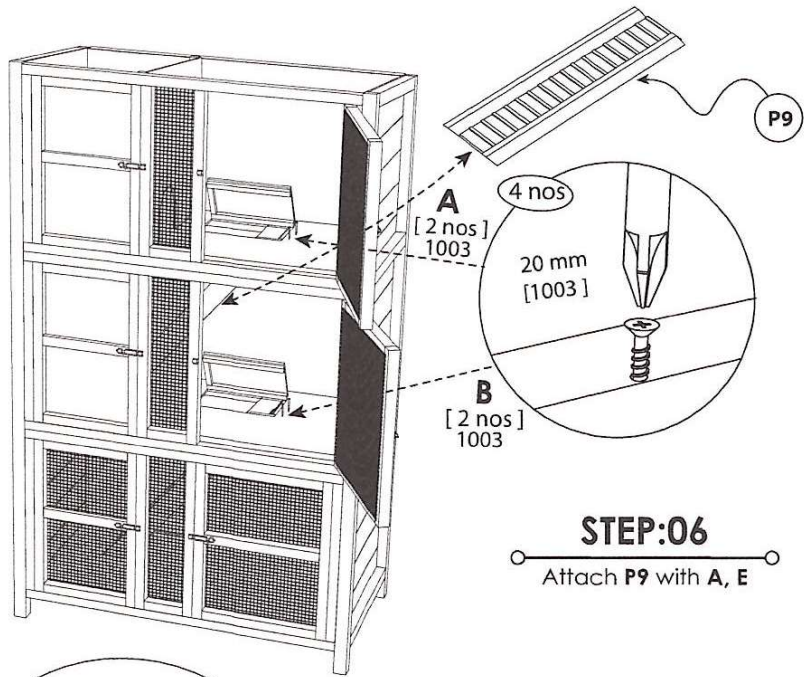

STEP:06
Attach P9 with A, E

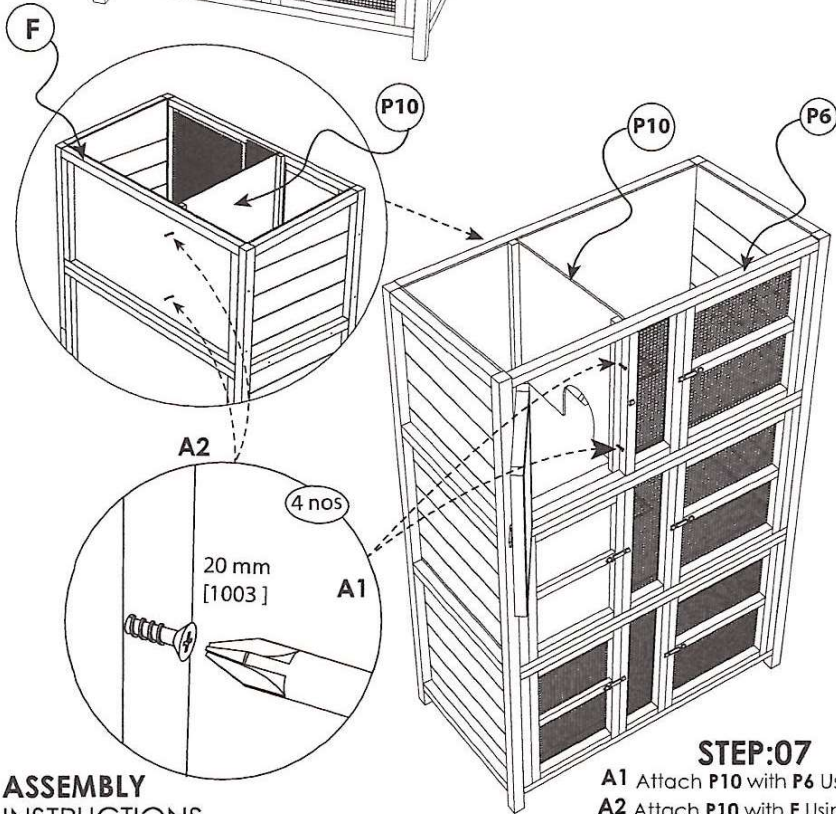

STEP:07
A1 Attach P10 with P6 Using 1003-2 nos
A2 Attach P10 with F Using 1003-2 nos

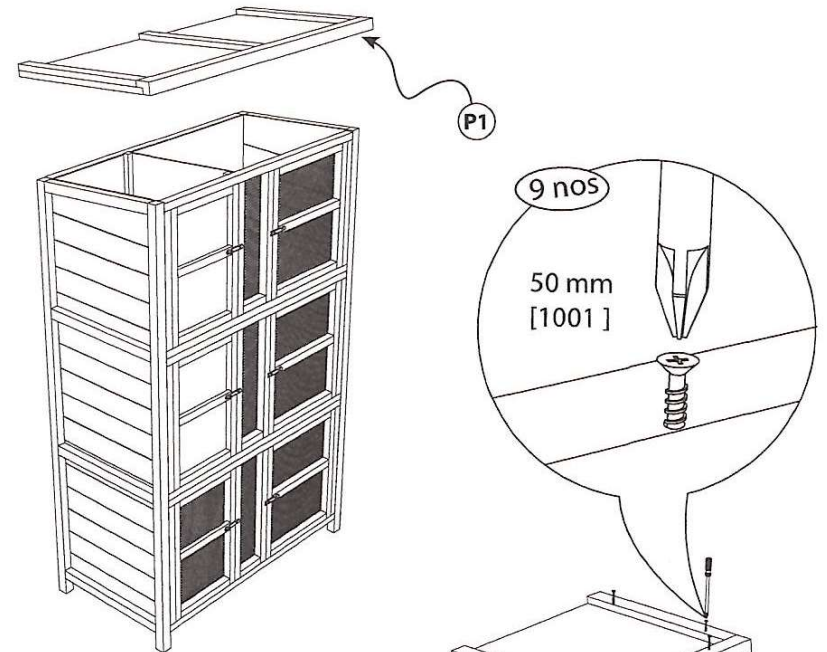

STEP:08
Attach P1 in following Position

